



HTM INTERNATIONAL MOLD SERVICE AND MANUFACTURE COMPANY LIMITED

HỒ SƠ NĂNG LỰC CÔNG TY

COMPANY PROFILE



SƠ ĐỒ TỔ CHỨC CÔNG TY ORGANIZATIONAL CHART

**GIÁM ĐỐC
(DIRECTOR)**

**HÀNH CHÍNH TỔNG HỢP
(GENERAL
ADMINISTRATION)**

**KINH DOANH
(BUSINESS DEPARTMENT)**

**PHÒNG KỸ THUẬT
(TECHNICAL
DEPARTMENT)**

**SẢN XUẤT KHUÔN
(MOLD MAKING)**

**KẾ TOÁN
(ACCOUNTING)**

**PHÁT TRIỂN THỊ
TRƯỜNG
(MARKET
DEVELOPMENT)**

**THIẾT KẾ
(DESIGN DEPT)**

**TRONG NƯỚC
(DOMESTIC)**

**NHÂN SỰ
(PERSONNEL)**

**CHĂM SÓC KHÁCH
HÀNG (CUSTOMER
CARE)**

**LẬP TRÌNH
(CAM)**

**NƯỚC NGOÀI
(FOREIGN)**

**BAN ISO
(ISO DEPT)**

BÁO GIÁ (QUOTE)

**(PHÁT TRIỂN
SP) PRODUCT
DEVELOPMENT**

**BỘ PHẬN QC.
(QC DEPT)**

DEVELOPMENT TREND – SALES DISTRIBUTION

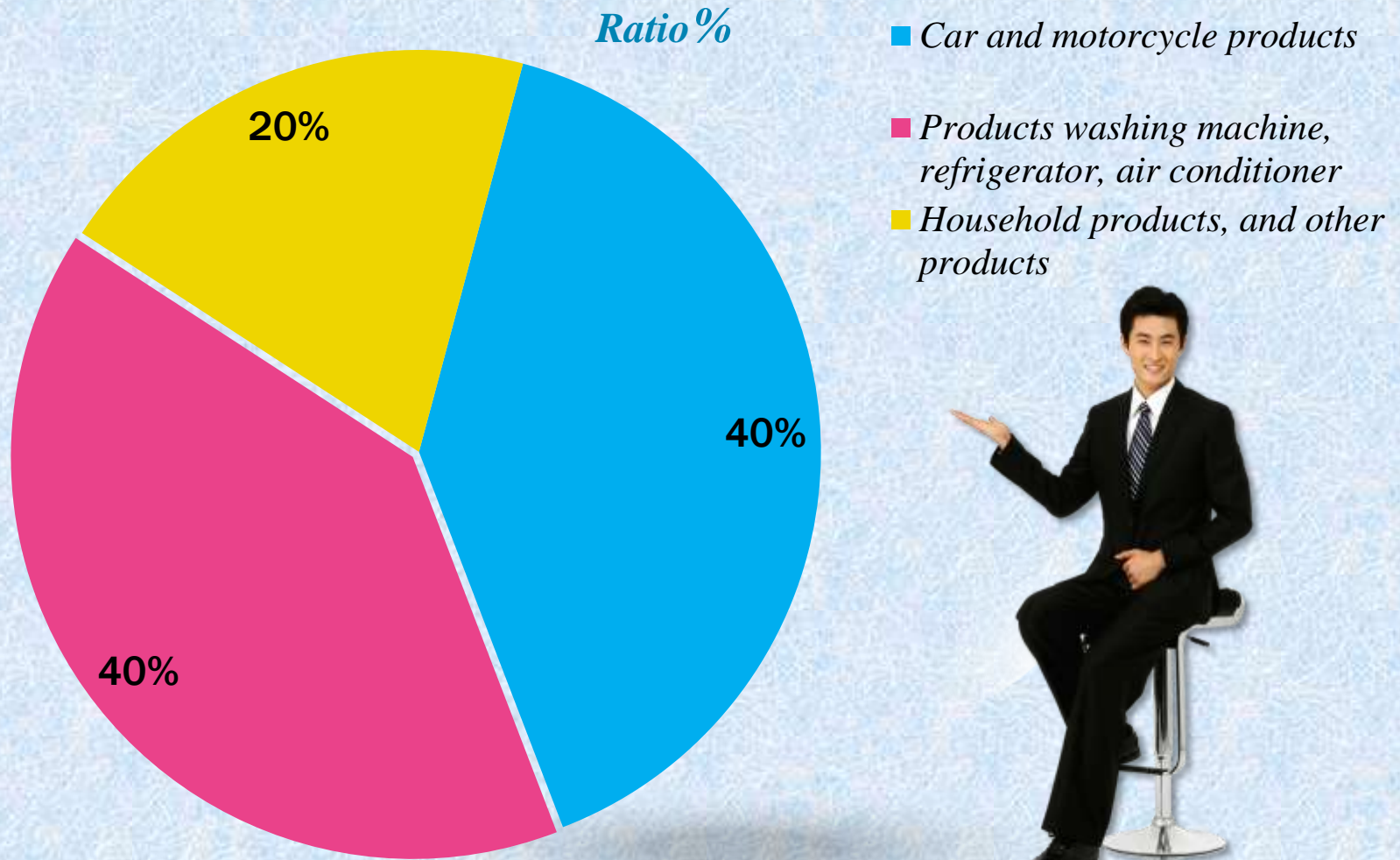

SOME OF THE MAIN CUSTOMERS



Number of employees



- **Technical team : 10 people**
- **Staff : 30 people**
- **Sales team : 4 people**



DESIGN PROCESS - MOLD PROCESSING

I

Receive information

- >> *Product drawings*
- >> *Technical requirements*
- >> *Mold Quotation*
- >> *Planning*

II

Prepare design

- >> *Analysis of CAE*
- >> *Up the mold texture*
- >> *Make layout drawings*
- >> *Meeting DFM*

III

Mold design

- >> *Design 2D, 3D*
- >> *Check design data*
- >> *Publish drawings*
- >> *Buy supplies*

IV

Preparing for processing

- >> *Study drawings*
- >> *Cam programming.*
- >> *Check Cam Program*
- >> *Machining planning*

V

Machining

- >> *Shape the work piece*
- >> *CNC Machining*
- >> *EDM . Machining ,WC..*
- >> *Polish.*

VI

Assembling and testing mold

- >> *Components control*
- >> *Assemble*
- >> *Complete*
- >> *Try molding*

VII

Product Reviews

- >> *Appearance rating*
- >> *Measure the size*
- >> *Assembly Review*
- >> *make a repair plan.*

Design software

CAE analysis software: Moldex 3D .
Design software: CIMATRON, NX .

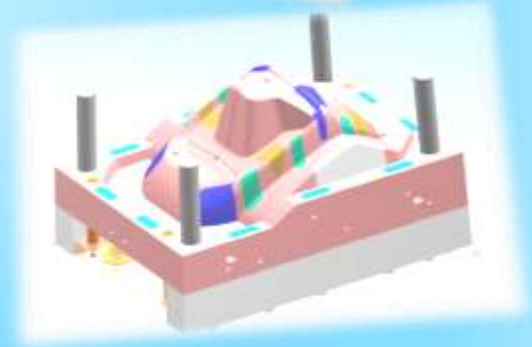
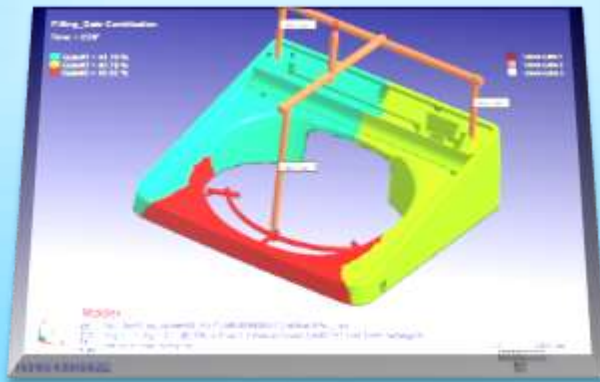
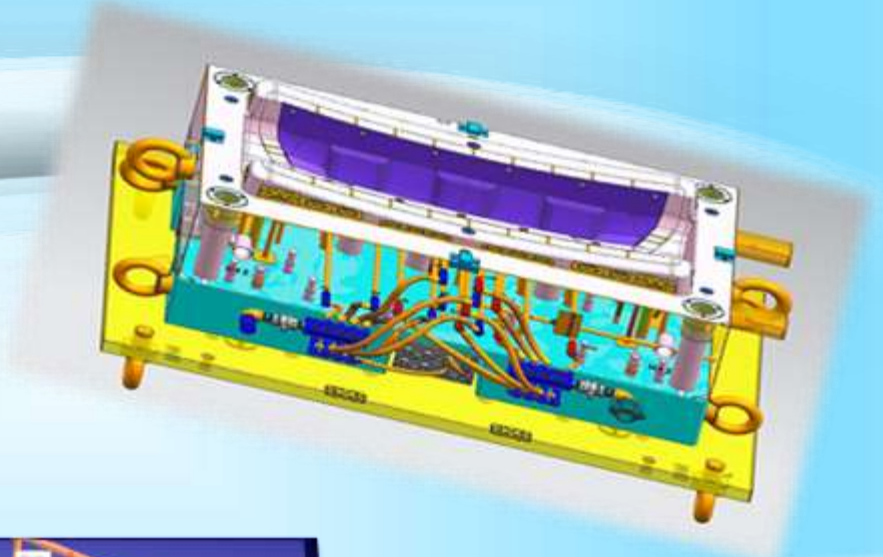
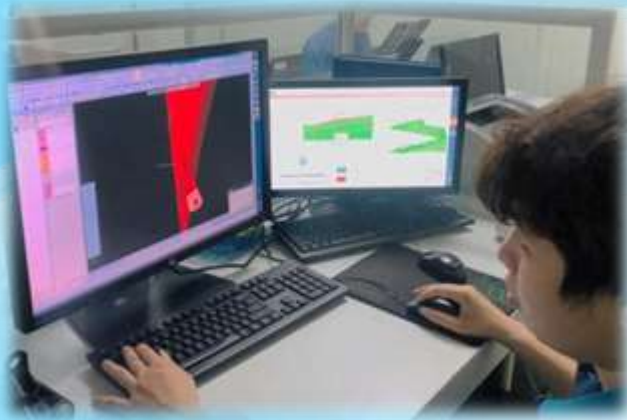



ISO CERT
Hài Hòa Công Thịnh Vượng

GIẤY CHỨNG NHẬN

Số 9199529343584-QMS

CHỨNG NHẬN HỆ THỐNG QUẢN LÝ CHẤT LƯỢNG CỦA
CÔNG TY TNHH SẢN XUẤT VÀ DỊCH VỤ KHUÔN QUỐC TẾ HTM

Trụ sở chính và địa chỉ Xưởng: Khu phố Đức Hiệp, Phường Xuân Lâm, Thị xã Thuận Thành, Tỉnh Bắc Ninh, Việt Nam.

Được đánh giá và xác nhận phù hợp với yêu cầu của tiêu chuẩn:

ISO 9001:2015

PHẠM VI CHỨNG NHẬN:

SẢN XUẤT VÀ SỬA CHỮA KHUÔN MẪU ÉP NHỰA.

Ngày chứng nhận : 16.11.2023
Ngày phát hành : 16.11.2023
Ngày hết hạn : 15.11.2026
Chi tiết tại quyết định số : 161123.05/QĐ-ISO CERT



Mã Truy Xuất Chứng Chỉ
9199529343584



VICAS 067-QMS



ISO 9001:2015



Ths. Vũ Hoàng Tuấn

Trà cứu hiệu lực chứng chỉ tại: <http://isocert.org.vn/ta-cuu-hieu-luc-chung-chi-lao>

CÔNG TY CỔ PHẦN CHỨNG NHẬN VÀ GIÁM ĐỊNH QUỐC TẾ ISO CERT

Số 46 dẫy A, Lũ 12 KĐT mới Dịch Công, Phường Dịch Công, Quận Hoàng Mai, Thành phố Hà Nội

Hotline: 1900.636.538, VP HN: 02473.036.538, VP HCM: 02873.036.538, Email: contacts@isocert.org.vn, Website: <http://isocert.org.vn>



ISO CERT
Harmonization And Prosperity

CERTIFICATE

No. 9199529343584-QMS

THIS IS TO CERTIFY THAT THE QUALITY MANAGEMENT SYSTEM OF
**HTM INTERNATIONAL MOLD SERVICE AND MANUFACTURE
COMPANY LIMITED**

Head office and Factory address: Duc Hiep Quarter, Xuan Lam Ward, Thanh Thanh Town, Bac Ninh Province, Vietnam.

Has been assessed and found to conform with requirements of the following standard:

ISO 9001:2015

SCOPE CERTIFIED:

PRODUCTION AND REPAIR OF PLASTIC INJECTION MOLDS.

Certification date : 16.Nov.2023
Issue date : 16.Nov.2023
Expiration date : 15.Nov.2026
Details in decision No. : 161123.05/QĐ-ISO CERT



Retrieval Information Code:
9199529343584



VICAS 067-QMS



ISO 9001:2015



Ms. Vu Hoang Tuan

Check the validity of the certificate: <http://isocert.org.vn/ta-cuu-hieu-luc-chung-chi-lao>

ISO CERT INTERNATIONAL CERTIFICATION AND INSPECTION JOINT STOCK COMPANY

No 40 A Row, Block 12, Dich Cong New Urban Area, Dich Cong Ward, Hoang Mai District, Hanoi

Hotline: 1900.636.538, Hanoi office: 02473.036.538, HCM office: 02873.036.538, Email: contacts@isocert.org.vn, Website: <http://isocert.org.vn>

THE MACHINES LIST

No	Machine name	Quantity (set)	Brand
1	CNC Rough Maching	01	Taiwan
2	CNC High Milling	02	Taiwan
3	Electrode processing machine	01	Taiwan
4	EDM CNC Machine	02	Taiwan
5	Surface Grinder	02	Taiwan
6	Die spotting	01	Taiwan
7	Drill Machine	01	Taiwan
8	Tig Welding 400 J98	01	China
9	Laze Welding 1500W	01	China
	Total	12	

MACHINE PICTURES



Some pictures in the processing stages



CNC gia công thô



Material Hardness Testing & Size Measuring



CNC Finish Milling



Deep hole drilling

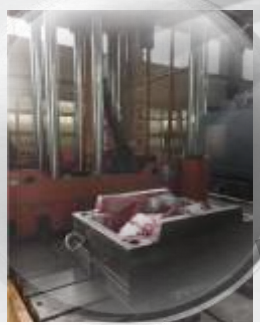

Mould match



EDM



Engraving

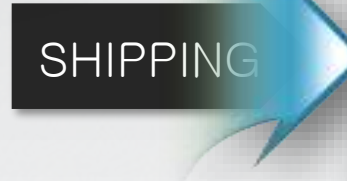

Polishing



Mould trial



Mould Disassembling Inspection Before Shipment



oiling & packing, Shipment

Pictures of molds and automotive products



Automotive product



Name: Dash board
Spec: Deep cavity large mould



Name: High Gloss Grille
Spec: Large exterior product



Name: Bumper
Spec: Deep cavity large mould

Automotive product mold

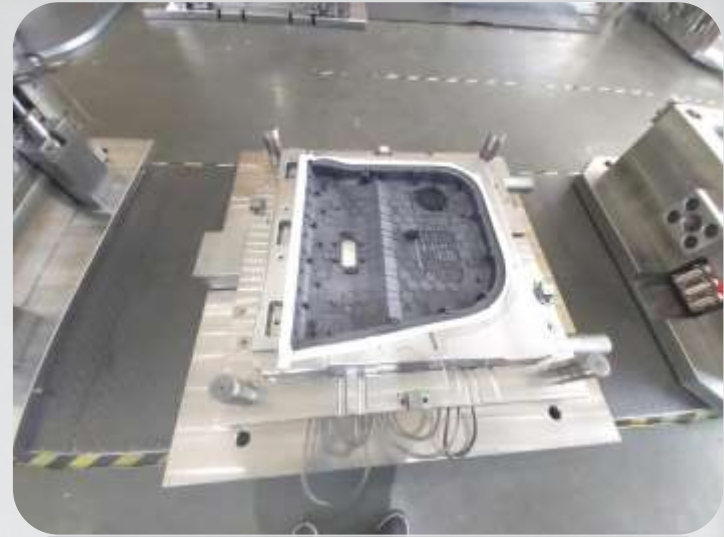
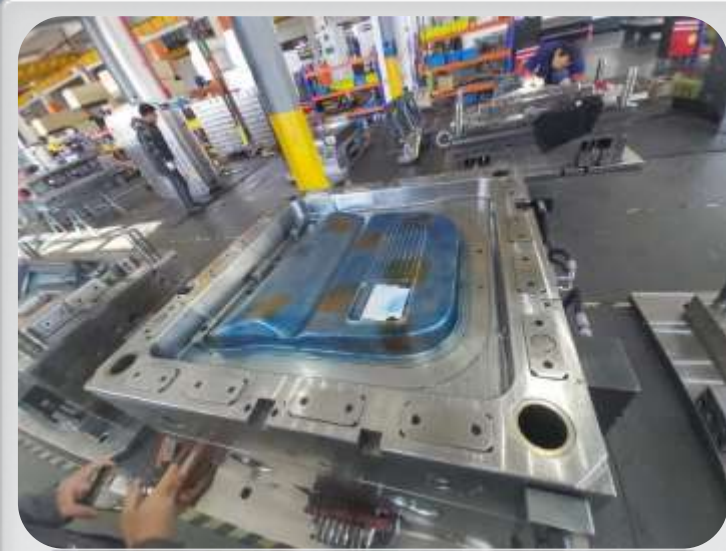

Motorcycle product pictures



Images mold

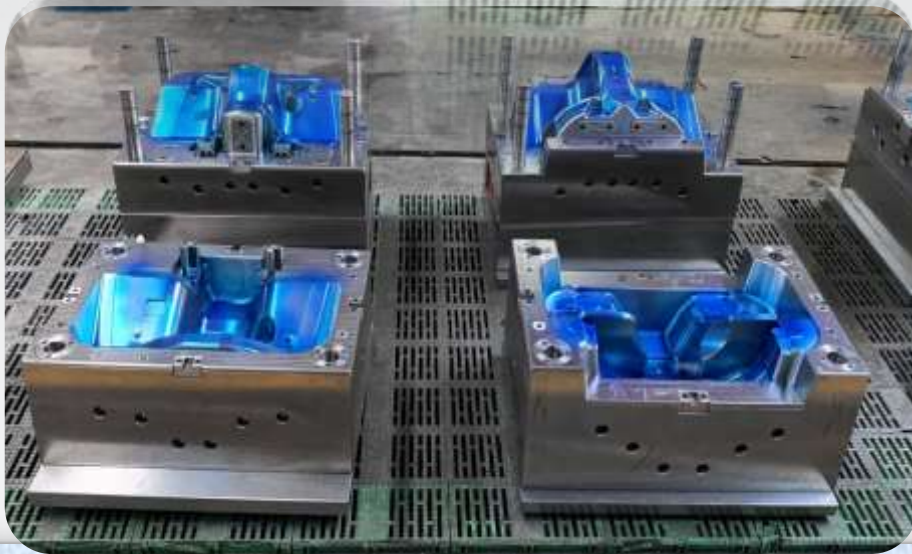

Product images of washing machine



Detailed product pictures of refrigerators

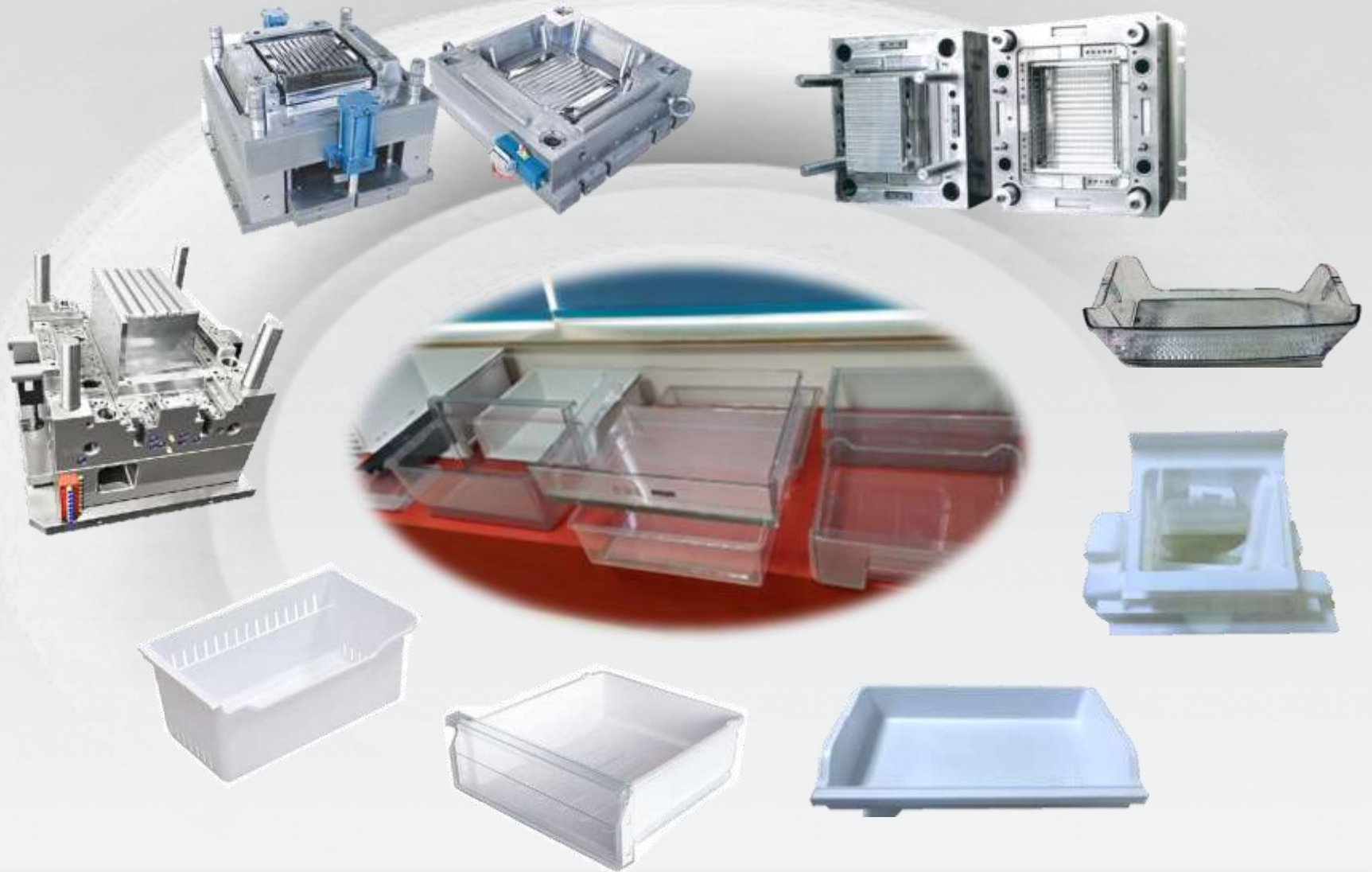

Household products

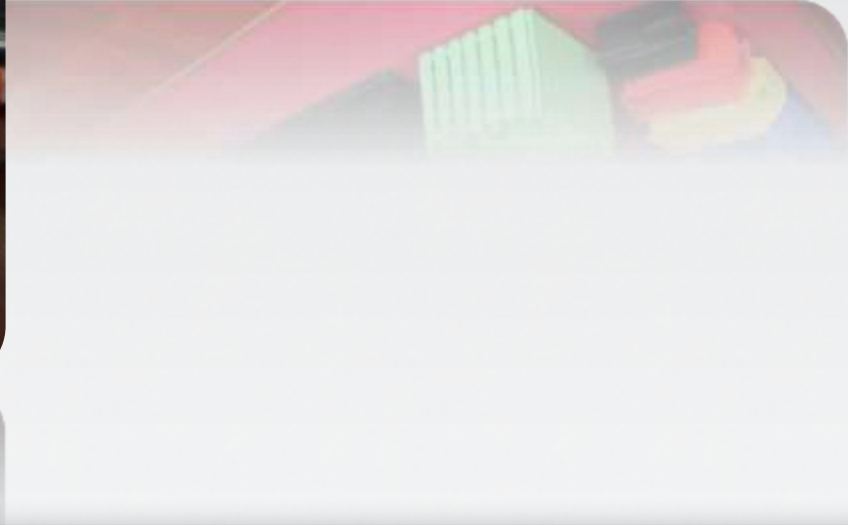

Pallet Mold

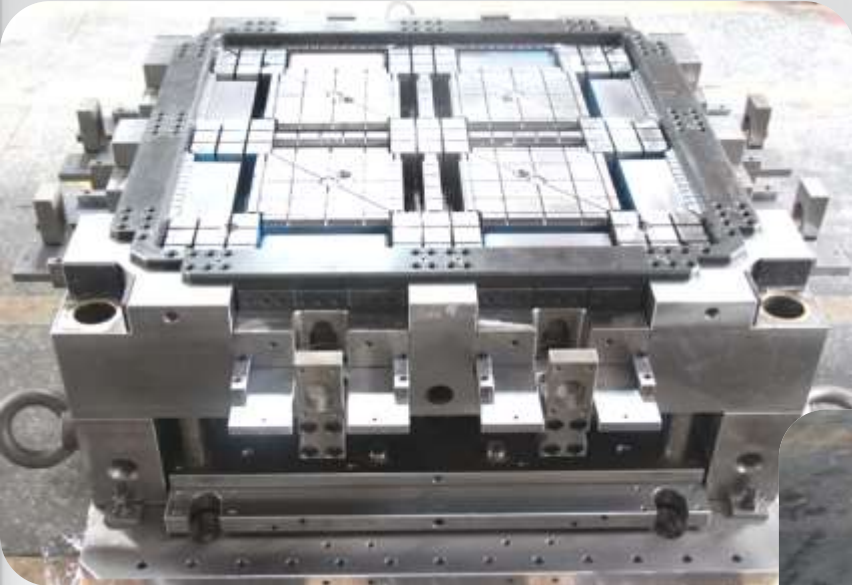

Quality Policy

Because of long-term cooperation and development, HTM MOLD is committed to providing products and services that meet customers' needs by mobilizing all resources into the plan, continuously innovating and constantly creating.



Thank you for listening



Looking forward to a
long-term cooperation
with you

HTM INTERNATIONAL CO.,LTD
Duc Hiep, Xuan Lam, Thuan Thanh, Bac Ninh
Tel :0989740006
Email: trungdung.gd@htm-int.vn
Sale01@htm-int.vn